

The M.2 module is based on Artix-7 FPGA that provides bridging features between PCIe and SD3.0 units to validate different memory densities of micro SD card. For host processor communication, the module is designed with 2-lane PCIe Gen 2.0 interfaces. The module presents compact design, flexibility, and consumes low power. Since it is PCIe backward compatible with the earlier version the user can integrate into existing systems with ease. The interface towards the SD card is realized by the SD protocol implemented in the FPGA.

HIGHLIGHTS

- 2280 M.2 M Keyed module form factor
- Compliant with SD3.0 standard specification
- Supports 2-Lane PCIe Gen2 link
- Supports both standard and high-capacity SD operations
- Supports data rate up to SDR 104/UHS-1

SPECIFICATIONS

Features
Supports legacy version of SD specification
ARTIX-7 FPGA to implement PCIe to SD3.0 bridge functionality
Micro SD slot to support the different memory density SD card
1x 10 pin GPIO Header to define functionality as per user requirement
Input Power: 3.3V@2.5A
Keying: M.2 Key M
Temperature Supported
-40C to +85C Industrial
Form Factor: 22mm x 80mm
Cooling: Conduction cooling using heat sink on the FPGA device

SD Operations



iW PCIe to SD 3.0 M.2 Module Block Diagram

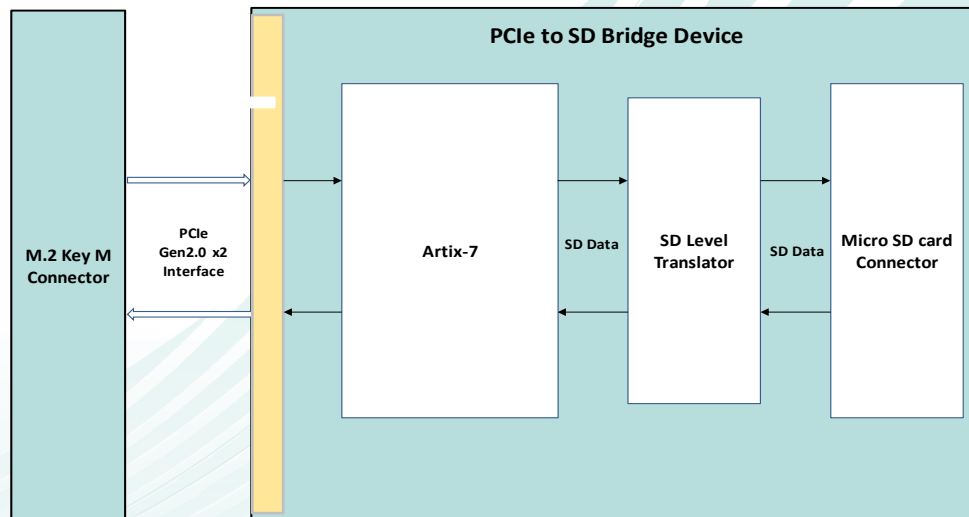

OS SUPPORT
Linux

DELIVERABLES
PCIe to SD 3.0 M.2 module
Heat sink
User Manual

ORDERING PART NUMBER
iW-M2SD-8GB-AR7-R1.0

iWave Systems Technologies is an ISO 9001:2015 certified company, head quartered in Bangalore India established in the year 1999. The company focuses on providing embedded solution and services for Industrial, Medical, Automotive and various other Embedded Computing applications. iWave Systems offers wide range of System On Modules and Single Board Computers built using wide range of CPU and FPGA SoC platforms with different form factors such as Qseven, SMARC, SODIMM and HPC by closely working with Tier-1 silicon companies such as NXP, Xilinx, Intel etc.

iWave Systems offers various state of art ready ODM solutions such as Connected Telematic Control Unit / OBD II devices for the automotive edge analytics, Comprehensive ARINC818 solutions for the low latency Aerospace applications and Rugged IP rated performance scalable HMI solutions for Industrial applications.

iWave Systems also provides comprehensive Engineering design services involving Embedded Hardware, FPGA and Software development. iWave offers carrier board and custom hardware development with manufacturing and certification services. iWave's Hardware expertise spans complex board design up to 30 layers; Analog, Digital & RF Designs; FPGA Development up to 3+ million gates and VHDL / Verilog RTL Development & Verification. Our Software expertise ranges from OS Porting, Firmware & Device Drivers Development and Wireless & Protocol stacks.

Note: iWave reserves the right to change these specifications without notice as part of iWave's continuous effort to meet the best in breed specification. The registered trademarks are proprietary of their respective owners.

iW-PCIe to SD 3.0 M.2 Module

The device can be ordered online from the iWave Website
<https://www.iwavesystems.com/product/pcie-to-sd-3.0-m.2-module/>
 Or from our Local Partners in your region
<http://www.iwavesystems.com/about-us/business-partner.html>

INDIA
iWave Systems Tech. Pvt. Ltd.,
7/B, 29th Main, BTM Layout
2nd Stage, Bangalore-560076
Email: mktg@iwavesystems.com

JAPAN
iWave Japan, Inc.
8F-B, Kannai Sumiyoshi Building,
3-29, Sumiyoshi-cho, Naka-ku,
Yokohama, Kanagawa, Japan.
mktg@iwavesystems.com

EUROPE
International Sales & Marketing Europe
Venkelbaan 55 2908KE Capelle
aan den IJssel
The Netherlands
info@iwavesystems.eu

USA
iWave USA
1692 Westmont Ave.,
Campbell, CA95008
USA
info@iwavesystems.us