

System On Module iW-RainboW-G40M

i.MX 8M Plus OSM LGA Module



The i.MX 8M Plus SoC based LGA Module is designed as per The Open Standard Module™ specification (OSM). It integrates NXP's i.MX 8M Plus offerings Quad/ QuadLite /Dual Cortex A53 @ up to 1.8GHz, NPU with up to 2.3 TOP/s, HDR capable Image Signal Processor (ISP) with IEEE 802.11 a/b/g/n/ac/ax* Wi Fi & BT 5.0 module.

The i.MX 8M Plus OSM LGA module is aimed to offer for applications mainly focusing on Machine Learning, NPU and vision system, advanced multimedia and industrial automation with high reliability.

iW-RainboW-G40M HIGHLIGHTS

- i.MX 8M Plus Q/QL/DCPU with 64-bit ARMv8 Architecture
- NPU with up to 2.3 TOP/s Neural Network performance
- Up to 8GB LPDDR4 Memory
- IEEE 802.11a/b/g/n/ac/ax Wi-Fi & Bluetooth 5.0 (ax is optional)
- 10+ years of Product Longevity Program
- Excels in ML vision, edge intelligence & advanced multimedia applications.
- OSM v1.0 Size-L LGA Module.
- OSM v1.0 Size-L LGA Module with 45mm x 45mm form factor

SPECIFICATIONS

SoC	SPI x 2
i.MX 8M Plus Quad : 4 x Cortex-A53, 1 x Cortex-M7, GPU, VPU, NPU ,ISP & HiFi4 Audio DSP	CAN x 2
i.MX 8M Plus Quad Lite : 4 x Cortex-A53, 1 x Cortex-M7 & GPU	I2C x 2
i.MX 8M Plus Dual : 2 x Cortex-A53, 1 x Cortex-M7, GPU, VPU, NPU ,ISP & HiFi4 Audio DSP	OSM GPIOs
Memory & Storage	4 lane MIPI DSI x 1
LPDDR4 -2GB (Expandable up to 8GB)	4 lane MIPI CSI x 1*
eMMC Flash - 16GB(Expandable up to 256GB)	4 lane MIPI CSI x 1
Other	4 lane LVDS x 2
IEEE 802.11 a/b/g/n/ac/ax Wi-Fi & BT 5.2 (ax is optional)	I2S x 1
OSM LGA Features	UART x 4 (1 is Optional)
RGMI x 2	PWM x 1
USB 3.0 x 2	OS Support
USB 2.0 x 2	Linux 6.1.22 (or higher), Android 12 (or higher), Ubuntu 22.04 (or higher)
PCIe 3.0 x 1	General Features
SDIO x 2 (4 bit x 1, 8 bit x 1**)	Power Input
HDMI 2.0a TX x 1	5V, 2.5A through OSM LGA
	Form Factor
	45mm x 45mm (Size L)
	Operating Temperature
	-40°C to +85°C (Industrial)
	Environment Specification
	REACH & RoHS3 Compliant

Note:

Optional features are not supported in default configuration.

*4 lane MIPI CSI X 1 is Optionally available through vendor defined pins

**Optional feature

i.MX 8M Plus OSM LGA Module Block Diagram

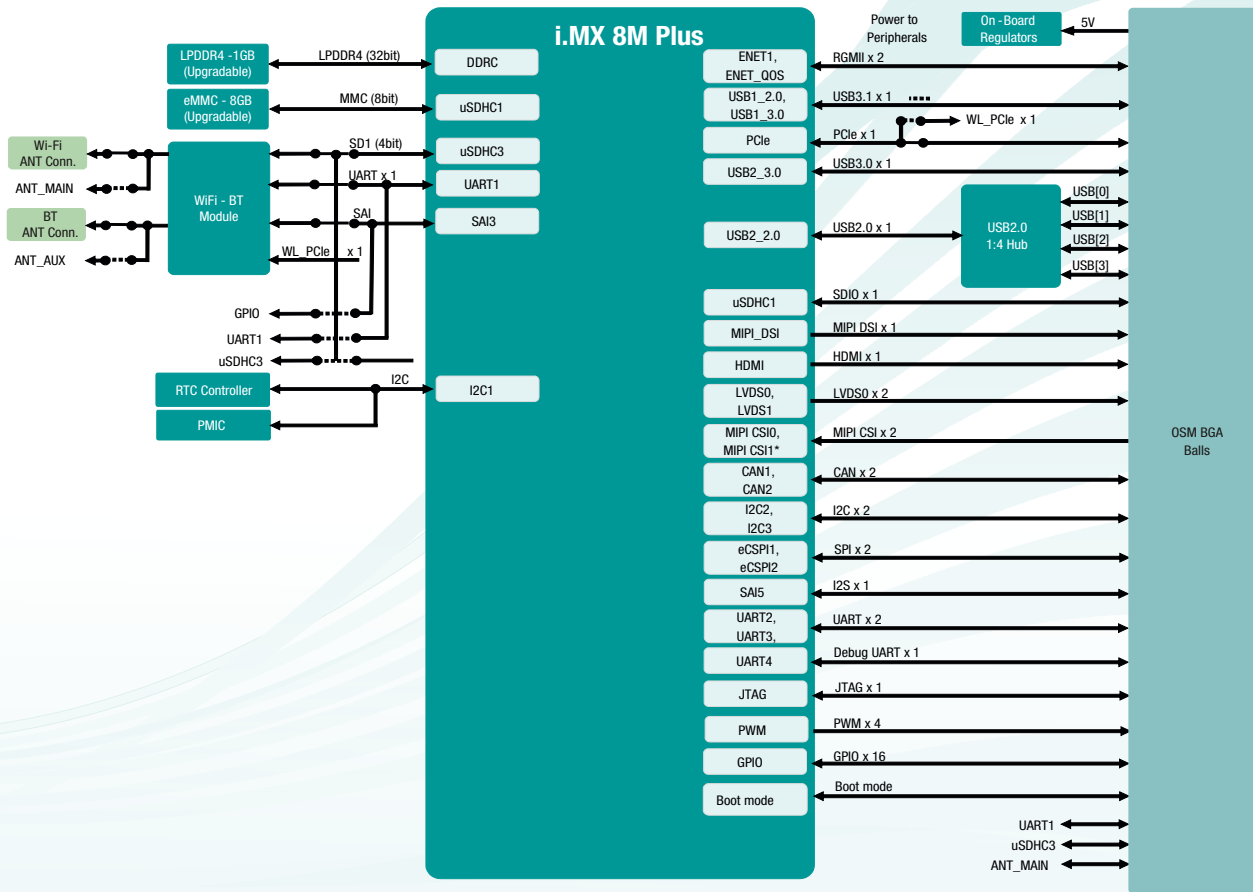

Note:
*Supported through Vendor Defined pins.

OS SUPPORT

Linux 5.4.24 (or higher)
Android 11 (or higher)
Ubuntu 20.04 (or higher)

DELIVERABLES

i.MX 8M Plus OSM Module
Board Support Package
User Manual

OPTIONAL KITS/Modules

i.MX 8M Plus OSM Development Kit
5.5" Cap touch Display
Heat Sink
Camera Module

CUSTOM DEVELOPMENT

BSP Development/OS Porting
Custom SOM/Carrier Development
Custom Application/GUI Development
Design Review and Support

iWave Systems Technologies is an ISO 9001:2015 certified company, head quartered in Bangalore India established in the year 1999. The company focuses on providing embedded solution and services for Industrial, Medical, Automotive and various other Embedded Computing applications. iWave Systems offers wide range of System On Modules and Single Board Computers built using wide range of CPU and FPGA SoC platforms with different form factors such as Qseven, SMARC, SODIMM and HPC by closely working with Tier-1 silicon companies such as NXP, Xilinx, Intel etc.

iWave Systems offers various state of art ready ODM solutions such as Connected Telematic Control Unit / OBD II devices for the automotive edge analytics, Comprehensive ARINC818 solutions for the low latency Aerospace applications and Rugged IP rated performance scalable HMI solutions for Industrial applications.

iWave Systems also provides comprehensive Engineering design services involving Embedded Hardware, FPGA and Software development. iWave offers carrier board and custom hardware development with manufacturing and certification services. iWave's Hardware expertise spans complex board design up to 30 layers; Analog, Digital & RF Designs; FPGA Development up to 3+ million gates and VHDL / Verilog RTL Development & Verification. Our Software expertise ranges from OS Porting, Firmware & Device Drivers Development and Wireless & Protocol Stacks.

*Optional items not included in the standard deliverables.

Note: iWave reserves the right to change these specifications without notice as part of iWave's continuous effort to meet the best in breed specification. The registered trademarks are proprietary of their respective owners.

i.MX 8M Plus OSM LGA Module

The device can be ordered online from the iWave Website
<https://www.iwavesystems.com/product/i-mx-8m-plus-osm-lga-module/>
Or from our Local Partners in your region
<http://www.iwavesystems.com/about-us/business-partner.html>

iW-G40M-BR-RT.1

INDIA

iWave Systems Technologies Pvt Ltd.
#7/B, 29th Main, BTM Layout
2nd Stage,
Bangalore - 560 076
mktg@iwavesystems.com

JAPAN

iWave Japan Inc.
8F Kannai Sumiyoshi Building,
3-29 Sumiyoshi-cho, Naka -ku,
Yokohama Kanagawa, Japan
mktg@iwavesystems.com

EUROPE

International Sales & Marketing Europe
Venkelbaan 55 2908KE Capelle
aan den IJssel,
The Netherlands
info@iwavesystems.eu

USA

iWave USA
1692 Westmont Ave. Campbell
Ca95008
USA
info@iwavesystems.us